

NEWTEC WEIGHING MACHINE

MD-SERIES

h3009MD / h3013MD

WIDTH OF WEIGH
HEADS 89 MM
HEIGHT OF WEIGH
HEADS 195 MM

ALSO AVAILABLE
FOR CHERRIES

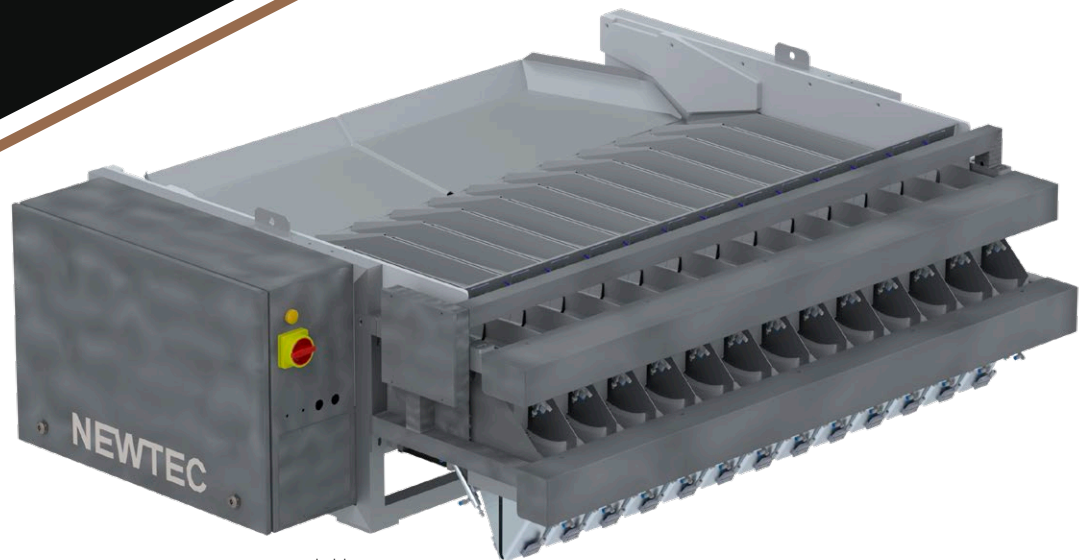

Model h3013MD



Gentle high speed weigher – for fragile products

Advantages

- Small machine with gentle product handling and low drops
- Combining speed and weighing accuracy
- High speed – up to 90 portions/min.at 0,5 kg (h3013MD)
- High weighing accuracy: Typical giveaway: less than 0.4%
- Robustly constructed in stainless steel
- Vibrator chutes for optimal distribution of products to the weigh heads
- Option: Newtec WebServices for remote servicing, data collection and analysis
- Option: Newtec MachineLink for easy control of more Newtec machines from only one touchscreen

Application

Washed vegetables and fruits such as:

- Tomatoes • Cherry tomatoes • Small potatoes • Nectarines • Clementines • Kiwi
- Plums • Nuts • Brussel Sprouts • Leeks • Peppers - and similar products
- Cherries (cherry kit)



WEBSERVICES AVAILABLE
FOR REMOTE SERVICING

YOUR ADVANTAGES

- User friendly software – programmable in seconds
- Count by weight, minimum weight or average weight programs
- Capable of running with one or more channels disabled
- Small V-shaped weigh heads with double opening for gentle handling of products
- Small footprint and low cost of ownership
- Option: “top pan tilt” for easy and quick access for cleaning and service



Model h3009MD
Option:
Cherry brush

SOLUTION FOR CHERRIES



- Round cherry brush for optimal handling of double cherries

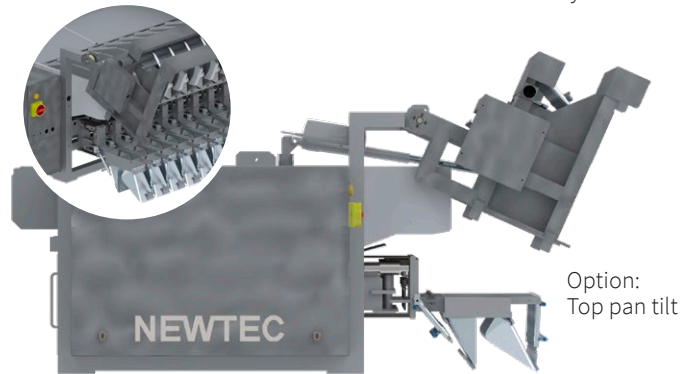

Option:
Top pan tilt

WEIGHING MACHINE WITH 9 / 13 CHANNELS

Model	h3009MD	h3013MD
Speed / Capacity	Up to 50 portions/ min. at 0,50 kg.	Up to 90 portions/ min. at 0,50 kg.
Weight	450 kg. (excl. portion collection system)	480 kg. (excl. portion collection system)

Portions sizes	0,25-1,0 kg (depending on product)
-----------------------	---------------------------------------

Air requirement	
Connection	3/8"
Min. pressure	6 bar (0.6 Mpa)
Consumption	250 NL/min.

Weigh head volume	2,0 L
Weigh head width	89 mm

Material	According to the EU/FDA rules on food contact materials
-----------------	--

Protection class	IP54
-------------------------	------

Electrical requirement	3x220 VAC or 3x400 VAC (N)+PE
-------------------------------	----------------------------------

Environment	5° C – 35° C
--------------------	--------------

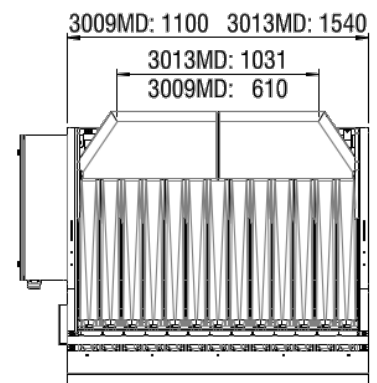
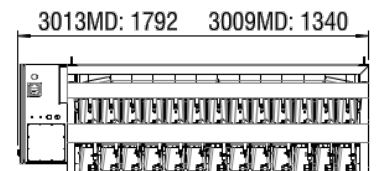
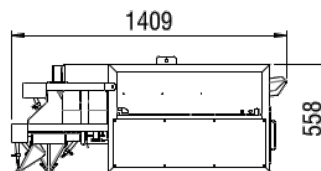

NEWTEC SOFTWARE

- Intuitive user interface
- Informative and upgradable
- Same user interface on all Newtec weighing and packing machines

